

ED Super Miniature Digital Display Unit

Compact R shaped smart design 7-segment display unit.

■ FEATURES

- Compact size 7-segment display unit.
- Depth behindpanel : 33mm
- Character height : 8mm
- Easily indicated by BCD codes.
- R shaped smart design with smoked cover gives good appearance for the panel.
- Red, Green, LED available.
- One-touch easy panel mounting with side plates.
- Terminal connection : IC pitch(2.54mm pitch) terminal for Connector.
- Display: 7-segment numerical unit, Character Unit.



DIMENSIONS / PANEL CUT-OUT

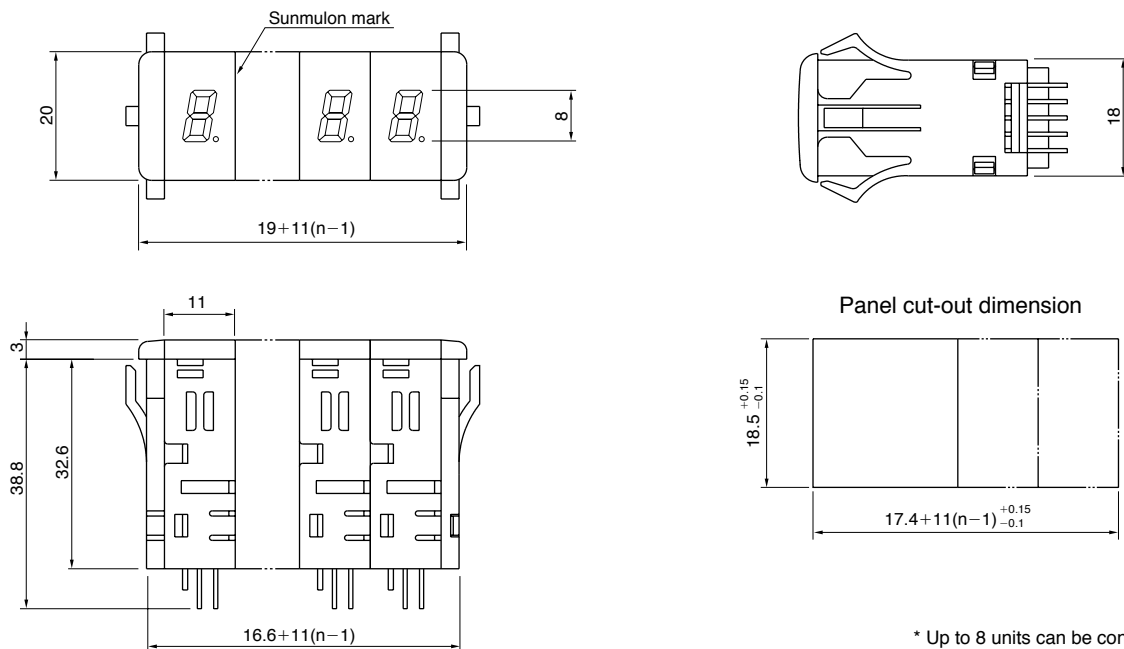

* Up to 8 units can be connected in series.
Panel thickness: 1.0~4.0mm
n: number of units

* Panel Cut Dimension should be after panel paintings.

Tolerance : $\pm 0.4\text{mm}$

SPECIFICATIONS

Numerical Unit (with circuit)

● Electrical Rating

Item	Type	ED-B□□1	ED-B□□2	ED-B□□3
Supply voltage		DC5V±5%	DC12V±10%	DC24V±10%
Current consumption		65mA MAX (1 unit)		
High level input voltage		3.5V~5V		
Low level input voltage		0V~1.5V		

● General Specification

Display pattern	● BCD Numerical unit 7-segment LED : 0~9, Decimal point
Luminous element	Red, Green
Input logic(Data only)	Positive, Negative
Ambient Temperature	-15~50°C
Ambient Humidity	80%RH

● Block Diagram

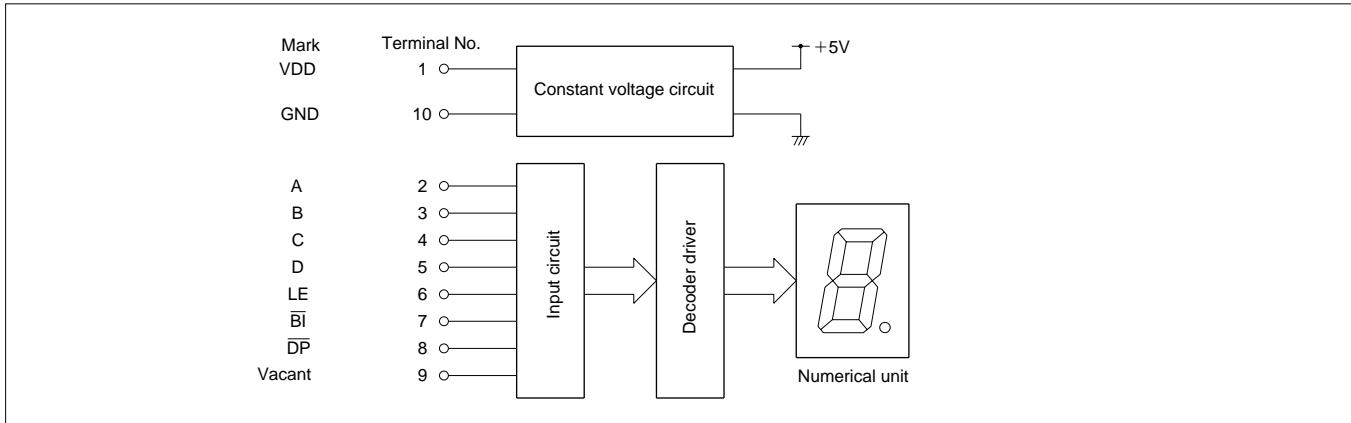

Note: 5V type has no Constant voltage circuit.

● Input circuit and connection

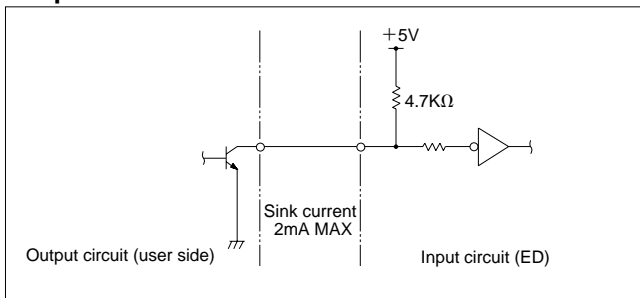

- Note
- 1) Since internal circuit is operated with +5V, user side output should be Open Collector Circuit, or less than +5V impression circuit.
 - 2) While power is not supplied in the unit, even low voltage not to be impressed on the input circuit.

● Input Timing

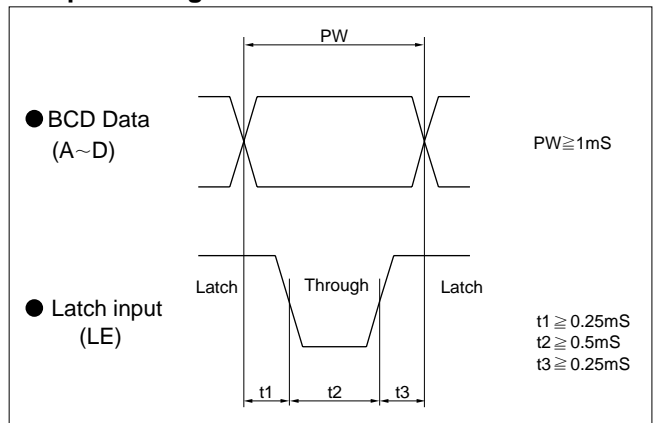

SPECIFICATIONS

● BCD Signals Truth Table

Input							Output
DP	B \bar{I}	LE	D	C	B	A	BCD
H	H	L	L(H)	L(H)	L(H)	L(H)	0
H	H	L	L(H)	L(H)	L(H)	H(L)	1
H	H	L	L(H)	L(H)	H(L)	L(H)	2
H	H	L	L(H)	L(H)	H(L)	H(L)	3
H	H	L	L(H)	H(L)	L(H)	L(H)	4
H	H	L	L(H)	H(L)	L(H)	H(L)	5
H	H	L	L(H)	H(L)	H(L)	L(H)	6
H	H	L	L(H)	H(L)	H(L)	H(L)	7
H	H	L	H(L)	L(H)	L(H)	L(H)	8
H	H	L	H(L)	L(H)	L(H)	H(L)	9
H	H	L	H(L)	L(H)	H(L)	L(H)	Blank
H	H	L	H(L)	L(H)	H(L)	H(L)	Blank
H	H	L	H(L)	H(L)	L(H)	L(H)	Blank
H	H	L	H(L)	H(L)	L(H)	H(L)	Blank
H	H	L	H(L)	H(L)	H(L)	H(L)	Blank
L	X	X	X	X	X	X	.
X	L	X	X	X	X	X	Blank
X	X	H	X	X	X	X	Latch Data (A-D) before 'H'

Note: 1) Either H, L is acceptable for X
2) () = Negative Logic

Character Unit

● LED Rating

Rated voltage	Rated current (mA)
	20
5V	20
12V	20
24V	20

● Connecting Circuit

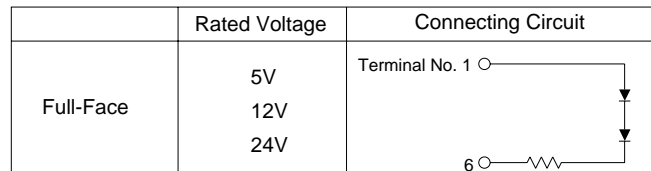

Numerical Unit(without circuit)

● LED Rating Absolute Maximum Rating

(Ta=25°C)

Item	Mark	Rating		Unit
		Red	Green	
DC forward current	IFDC/seg	15	20	mA
Pulse forward current*	IFP/seg	60	60	mA
DC reverse current	VR	3	3	V

* Duty ratio = 1/10 Pulse width = 1ms

● Electrical/Optical Performance

(Ta=25°C)

Item	Mark	Meas'ment Condition	Red	Green	Unit
Forward voltage	VF	IF=10mA	2.0	2.1	V
Reverse current	IR	VR=3V	Max.100	Max.100	μA
Luminous intensity/Segment	IV	IF=10mA	6.3	6.3	mcd
Peak radiation wavelength	λP	IF=10mA	610	563	nm
Spectral half-width	Δλ	IF=10mA	40	40	nm

● Connecting Circuit

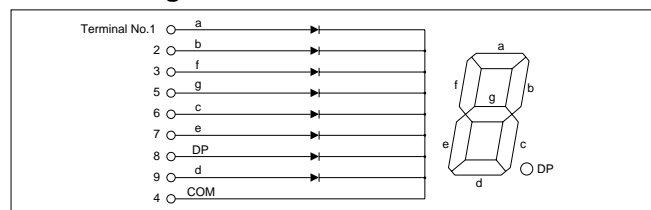

TERMINALS

● Terminals Arrangement

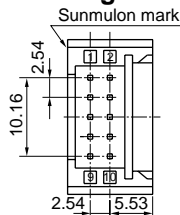

● Terminals shape

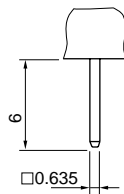

● Connector Set (Type No. BD-0556)

OMRON XG4M-1030 (Socket) XG4T-1004 (Strain Relief)
XG5Z-1002 (Lock Lever)

* Connectors are not appended, please procure above connector set or prepare equivalent.

● Terminals Function Table

Terminal No.	Mark	Description	Numerical Unit	Character Unit
			Functions	Anode(+)
1	VDD	⊕ Power supply	⊕ Power input	—
2	A(2 ⁰)	Data	● Indicate figures and symbols according to data signal input. See truth table.	—
3	B(2 ¹)			
4	C(2 ²)			
5	D(2 ³)			
6	LE	Latch	● 'H' makes latching data. ● 'L' makes data 'through'.	Cathode(-)
7	B \bar{I}	Blanking	● 'L' makes display 'OFF' except Decimal Point.	—
8	D \bar{P}	Decimal point	● 'L' makes Decimal Point 'ON'.	—
9			Vacant	—
10	GND	Ground	⊖ Power input. Electrical potential norm of all signals.	—

Tolerance : ±0.4mm

ORDERING CODE

Numerical Unit (with circuit)

BCD Numerical unit(B)



* Side plates to be ordered separately.

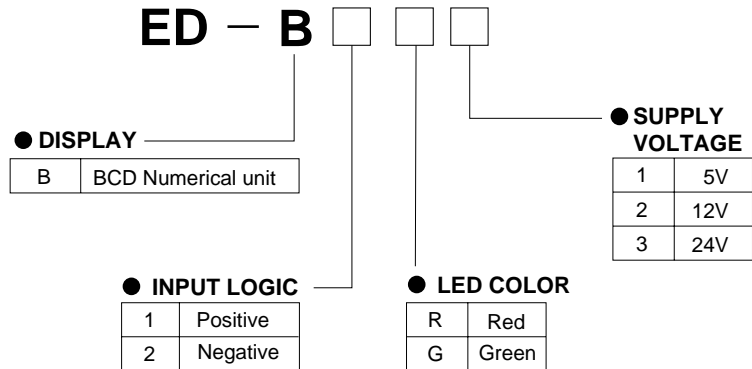

Character Unit



* Side plates to be ordered separately.

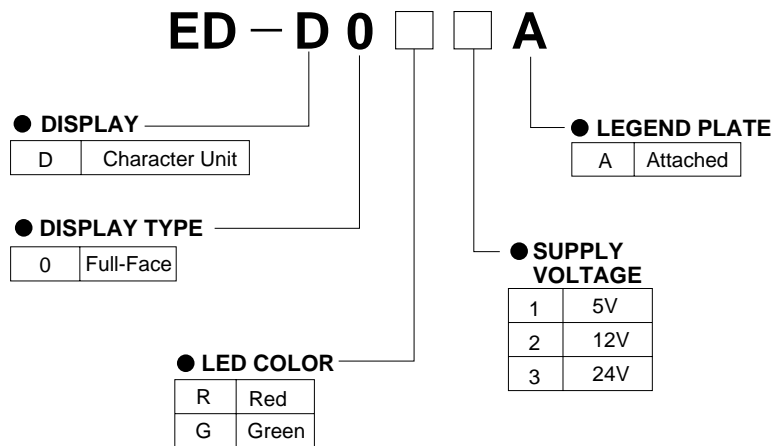

NUMERICAL UNIT (WITHOUT CIRCUIT)



* Side plates to be ordered separately.

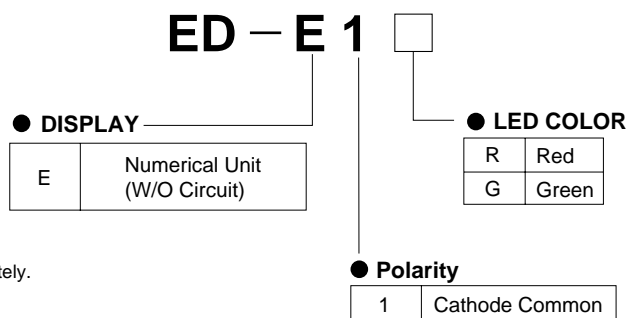

● SIDE PLATES

* A pair of Side Plate (Right/Left) is necessary for mounting on panel.

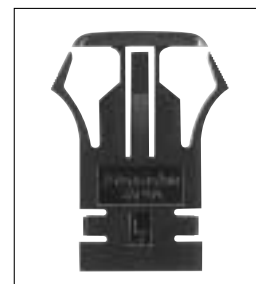

ED - 0120 - K

* A pair of Side Plate (Right/Left) be supplied by ordering above part no.